

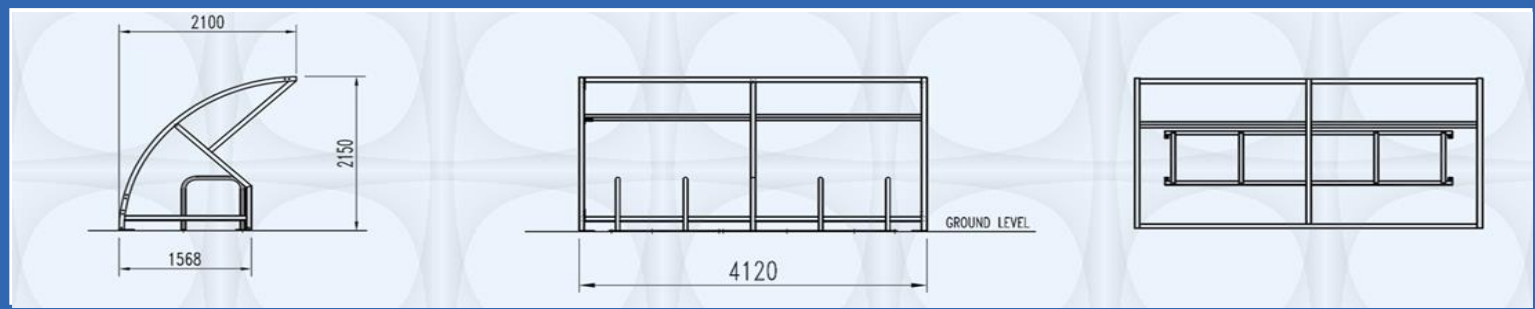

The Salisbury cycle shelter is manufactured from high grade 60mm x 60mm mild steel box section, galvanized BS EN ISO 1461 or zinc plated EN12329 -200 Fe/Zn8/a/c and powder coated BS EN ISO 9002 to a colour of your choice. Designed to offer an affordable solution for cycle storage, the Salisbury is of modular design and so additional shelters can be added to increase the desired cycle capacity of the shelter or create a secure compound with roof backs and gates.

The Salisbury is supplied with Sheffield toast rack cycle stands as standard and is glazed with PETG. Installed with either adjustable base plates for bolting down or extended legs for submerging into the ground.



Dimensions (mm)

Capacity	Height	Width	Depth
10	2150	4120	2100
14	2150	6150	2100
20	2150	8180	2100
24	2150	10210	2100
30	2150	12240	2100

Finishes

Galvanised	Powder Coated	Galvanised and Powder Coated
✓	✓	✓

Fixing Options

Surface Mounted	Sub Surface Fixed
✓	✓